

DYNAFLO® 6220S / 6230S
Model Numbers: 62201S, 62203S & 62303S

DEPEND ON
DAVEY

WATER PRODUCTS

TRANSFER PUMPS

PRODUCT DESCRIPTION

Rugged economical single stage centrifugal pumps. Designed for total heads to 40 m and flow to 440 lpm.

APPLICATIONS

- Water supply
- Water transfer
- Hosing down - dairies, factory floors etc.
- Tank filling
- Sprinkler supply
- Garden reticulation



Also available in 220 volt 60Hz single phase, 380 volt 60Hz three phase & 316SS.

FEATURES & BENEFITS

Every pump is performance and pressure tested in our factory to ensure quality and reliability.

Cast iron pump casing with baked enamel finish inside & outside for long life.

O-ring sealed hand tightened priming plugs for easy operation.

Proven, robust pump design for long life.

304 stainless steel pump shaft for longer life in aggressive water.

Davey manufactured motor with IP56-TEFC, 2 pole motor is corrosion resistant for long term protection against vermin, dust and water.

Motor and pump are designed for frequent starts providing a long and reliable working life.

In-built thermal overload protection with automatic reset in all single phase models for long term motor protection.

Double contact seal, C3, high temperature greased bearings for long life and smooth running.

2m power lead with 15amp Australian three pin plug fitted to all single phase models.

Single phase 62201S model is suitable for both 220-240 volt and 440-480 volt single phase supply.

Corrosion resistant motor mounting feet for long life.

OPERATING LIMITS

	6220S	6230S
Capacities to	350lpm	440lpm
Maximum total head	38m	40m
Maximum suction head		7.0m
Maximum Water Temperature		50°C
Minimum Water Temperature		1°C
Inlet size		2" BSP(F)
Outlet size		1 1/2" BSP(F)
Maximum Casing Pressure		105m



TECHNICAL SPECIFICATIONS

MATERIALS OF CONSTRUCTION

PART	MATERIAL
Impellers	Glass filled polycarbonate
Pump casing	Cast iron
Seal ring (stationary)	Ceramic
Seal ring (rotating)	Carbon
Shaft	304 stainless steel
Seal elastomer	Nitrile rubber
Pump orings	Nitrile rubber
Motor shell	Aluminium
Pump casing/shell finish	Baked enamel
Motor mounting feet	Xenoy® plastic
Motor through bolts	304 s/s with brass nuts
Motor fan	Polypropylene

HYDRAULIC PERFORMANCE

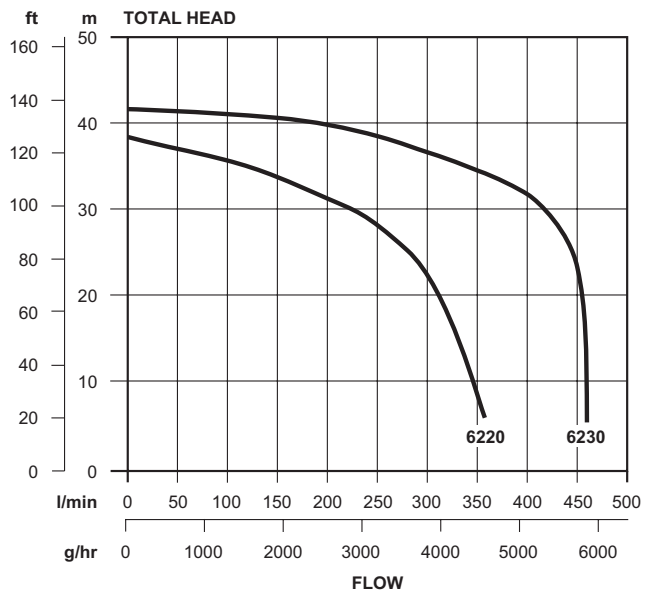

ELECTRICAL DATA

	6220S			6230S
	Supply voltage	220-240	440-480	380-415
Supply frequency	50Hz			
Phase	Single		Three	
Full load current	14A	7A	4.7A	6.3A
Locked rotor current	54A	27A	24A	47A
Input power	3.2kW	3.2kW	2.8kW	3.9kW
Output power	2.4kW	2.4kW	2.4kW	3.0kW
Insulation class	Class F			
Starting	P.S.C.		N/A	
IP rating	IP56			

DIMENSIONS

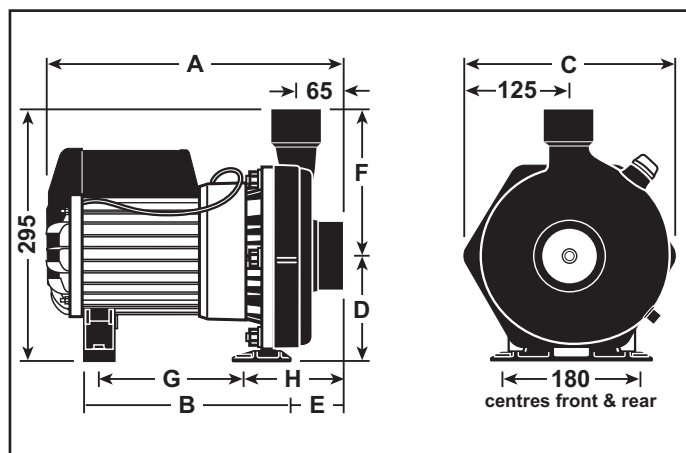

Model	A	B	C	D	E	F	G	H	Mounting Holes Dia. (mm)	Inlet B.S.P.	Outlet B.S.P.	Net Weight (kg)
62201S	415	280	250	125	70	175	223	130	10	2" F	1 1/2" F	32
62203S	385	250	250	125	70	175	223	130	10	2" F	1 1/2" F	28.5
62303S	445	310	250	125	70	175	223	130	10	2" F	1 1/2" F	33

All dimensions in mm unless otherwise stated.

INSTALLATION & PRIMING

- Installation with suction lift require a good quality foot valve to avoid loss of prime.
- To prime, fill pump body and suction line through priming plug hole located above suction inlet and replace plug.

This literature is not a complete guide to product usage. Further information is available from your Davey dealer, Davey Customer Service Centre and from the relevant product Installation and Operating Instructions. This data sheet must be read in conjunction with the relevant product Installation and Operating Instructions and all applicable statutory requirements. Product specifications may change without notice.

© Davey and Dynaflo are registered trademarks of Davey Water Products Pty Ltd. © Davey Water Products Pty Ltd 2000.



Visit Davey on-line for further information
davey.com.au

DEPEND ON
DAVEY

WATER PRODUCTS

Davey Water Products Pty Ltd

Member of the GUD Group
ABN 18 066 327 517
Head Office and Manufacturing
6 Lakeview Drive,
Scoresby, Australia 3179
Ph: +61 3 9730 9222
Fax: +61 3 9753 4100
Website: davey.com.au
Customer Service Centre
Ph: 1300 367 866
Fax: 1300 369 119
E-mail: sales@davey.com.au
Interstate Offices
Sydney • Brisbane • Adelaide
Perth • Townsville

International

6 Lakeview Drive,
Scoresby, Australia 3179
Ph: +61 3 9730 9121
Fax: +61 3 9753 4248
E-mail: export@davey.com.au

Germany

Kantstrasse 53,
04275 Leipzig
Ph: +49 341 301 0412
Fax: +49 341 301 0413
E-mail: akrenz@daveyeurope.com

New Zealand

7 Rockridge Avenue,
North Harbour, Auckland 1330
Ph: +64 9 570 9135
Fax: +64 9 527 7654
Website: daveynz.co.nz
E-mail: sales@daveynz.co.nz

USA - Davey Pumps Inc.

1005 N. Commons Drive
Aurora, Illinois 60504
Ph: +1 630 898 6976
Fax: +1 630 851 7744
Website: daveyusa.com
E-mail: sales@daveyusa.com