

**DYNAJET® SPEARPOINT PUMPS**  
**Models: Dynajet® XJ50, XJ70 & XJ90**  
**Build Prefix: 72501, 72701 & 72901**

DEPEND ON  
**DAVEY**

**TECHNICAL SPECIFICATIONS**



**DYNAJET® SPEARPOINT PUMPS**

**PRODUCT DESCRIPTION**

Economical, compact 50, 70 and 90 lpm single stage jet assisted centrifugal pumps.

**APPLICATIONS**

- Ideal for domestic irrigation from shallow wells or sand spears
- Overhead or high tank filling
- Pressure boosting
- Water transfer

**MATERIALS OF CONSTRUCTION**

PART	MATERIAL
Impellers	Glass filled polycarbonate
Pump casing	Glass filled Noryl
Pump shaft sleeve	Brass
Internal check valve	Delrin
Internal check valve spring	Stainless spring steel
Jet and Venturi	Acetal
Inlet & outlet ports	Glass filled Noryl
Seal ring (stationary)	Carbon
Seal ring (rotating)	Ceramic
Seal spring	304 Stainless Steel
Orings	Nitrile rubber

**ELECTRICAL DATA**

	XJ50	XJ70	XJ90
Supply voltage	220-240V		
Supply frequency	50Hz		
Input power (P <sub>1</sub> )	0.84kW	1.15kW	1.4kW
Output power (P <sub>2</sub> )	0.56kW	0.8kW	1.1kW
Full Load Current	3.6A	5.1A	6.6A
Locked Rotor Current	12.0A	18.0A	28.0A
Starting	P.S.C.		
Insulation class	Class F		
IP Rating	IP55		



**DIMENSIONS**

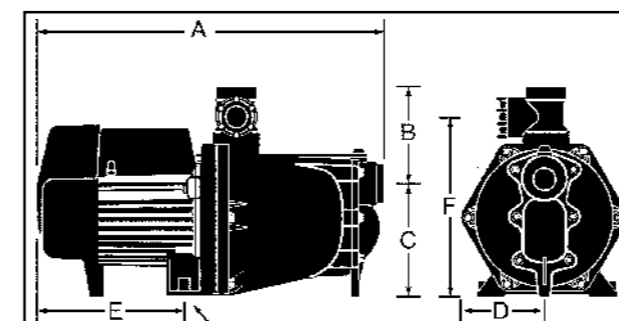

MODEL	A	B	C	D	E	F	Inlet BSP	Outlet BSP	Net Weight kg.
XJ50	430	124	146	102	185	226	1" F	1" F	8.5
XJ70	455	124	146	102	210	226	1" F	1" F	10.5
XJ90	505	124	146	102	260	226	1 1/4" F	1" F	13.5

All dimensions in mm unless otherwise stated.

**HYDRAULIC PERFORMANCE**

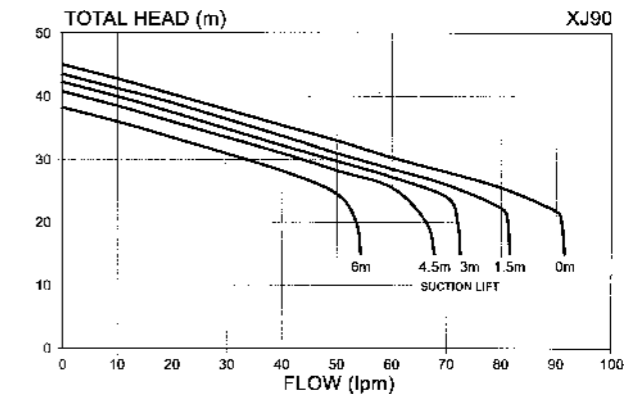
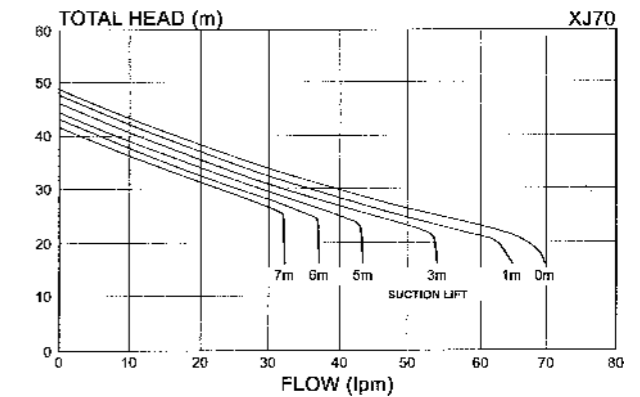
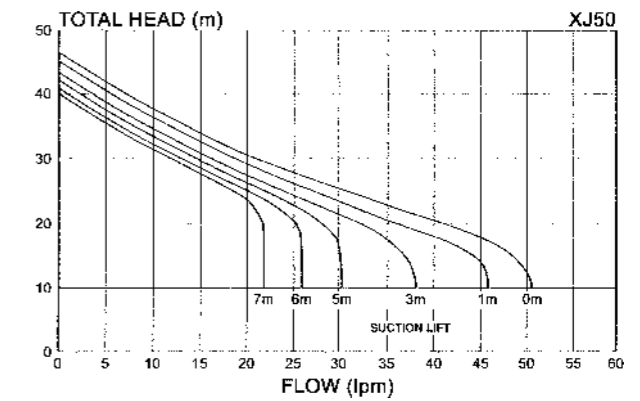

**INSTALLATION & PRIMING**

- On installations with suction lifts over 1m, a good quality foot valve or non-return valve should be fitted to the suction pipe.
- The system is primed by filling the pump and suction line with water through the priming port, and replacing priming plug prior to switching on.

Note: This literature is not a complete guide to product usage. Further information is available from your Davey dealer, Davey Customer Service Centre and from the relevant product Installation and Operating Instructions. This data sheet must be read in conjunction with the relevant product Installation and Operating Instructions and all applicable statutory requirements. Product specifications may change without notice.

© Davey is a registered trade mark of Davey Products Pty Ltd.  
 © Davey Products Pty Ltd 2000

**DESIGN FEATURES**

**PUMP**  
 Single stage jet assisted centrifugal with closed vane impeller.  
 Brass pump shaft sleeve.  
 Mechanical shaft seal.

**MOTOR**  
 Davey manufactured.  
 2 pole, 2850rpm, 50Hz.  
 TEFC with IP55 enclosure.  
 Class F insulation.  
 Permanently split capacitor design.  
 Double contact sealed C3-HTG rated ball bearings.  
 Protected against both high operating temperatures and high current by a built-in automatically resetting thermal overload.

**BENEFITS**

- Manufactured from highest quality corrosion resistant materials
- Compact foot print for quick and easy installation
- TEFC motor - corrosion resistant and excludes dust and dirt
- Motor and pump designed for frequent starts
- Every unit individually tested to guarantee reliable operation
- Low maintenance
- Easy to service if required
- Reliable and proven performance.

**OPERATING LIMITS**

MODEL	XJ50	XJ70	XJ90
Capacities to	50lpm	70lpm	90lpm
Maximum Total Head	46m	48m	46m
Maximum Liquid Temp.	50°C		
Maximum Ambient Temp.	55°C		
Maximum Suction Lift	7m		
Inlet size (BSP)	1" F	1" F	1 1/4" F
Outlet size (BSP)	1" F	1" F	1" F



DEPEND ON  
**DAVEY**

**Davey Products Pty Ltd**  
 Member of the GUD Group  
 ABN 18 066 327 517  
**Head Office and Manufacturing**  
 No 6 Lakeview Drive,  
 Caribbean Gardens,  
 Scoresby, Australia 3179  
 Ph: +61 3 9730 9222  
 Fax: +61 3 9753 4248  
 AH: +61 3 9730 9121  
 E-mail: export@davey.com.au  
**Germany**  
 Kantstrasse 47,  
 04275 Leipzig  
 Ph: +49 341 301 0412  
 Fax: +49 341 301 0413  
 E-mail: DaveyEuropa@aol.com  
**Jordan**  
 P O Box 6822 Amman 11118  
 Ph/Fax: +962 6 566 6858  
 E-mail: davey-jo@joinnet.com.jo

**International**  
 No 6 Lakeview Drive,  
 Caribbean Gardens,  
 Scoresby, Australia 3179  
 Ph: +61 3 9730 9222  
 Fax: +61 3 9753 4248  
 AH: +61 3 9730 9121  
 E-mail: export@davey.com.au  
**Germany**  
 Kantstrasse 47,  
 04275 Leipzig  
 Ph: +49 341 301 0412  
 Fax: +49 341 301 0413  
 E-mail: DaveyEuropa@aol.com  
**Jordan**  
 P O Box 6822 Amman 11118  
 Ph/Fax: +962 6 566 6858  
 E-mail: davey-jo@joinnet.com.jo

**New Zealand**  
 8 Ashfield Street,  
 Glenfield, Auckland 1310  
 Ph: +64 9 444 3622  
 Fax: +64 9 444 2179  
 Website: www.daveynz.co.nz  
 E-mail: sales@daveynz.co.nz  
**U.S.A.**  
 3847 Exchange Avenue  
 Aurora, Illinois 60504  
 Ph: +1 630 898 6976  
 Fax: +1 630 851 7744  
 Toll Free: +1 866 328 7867  
 Website: www.daveyusa.com  
 E-mail: sales@daveyusa.com