

DEPEND ON  
**DAVEY**

**WATER PRODUCTS**



# Installation and Operating Instructions for **Aquashield<sup>®</sup> MAX** Packaged Ultra Violet Water Treatment System incorporating **RainBank<sup>®</sup>** and **Torrium<sup>®</sup>** **Controllers, Filterpure<sup>®</sup>** **Filters and Steriflo<sup>®</sup> Disinfection**



Maximum operating pressure for stainless steel UV chambers is 850kPa (125 psi). If this pressure can be exceeded or if operating close to this pressure fit a suitable pressure limiting valve in the supply to the UV chamber or mains water line.



**WARNING:** The pump, controller & UV Chamber operate under pressure. Under no circumstances should they be disassembled unless the internal pressure of the unit has been relieved. Failure to observe this warning will expose persons to the possibility of personal injury and may result in damage to the system or other property.



Ultra violet radiation is harmful to skin & eyes.  
**DO NOT LOOK AT UV LAMP WHILE LAMP IS OPERATING.**



**DO NOT DISASSEMBLE ANY COMPONENTS UNTIL YOU HAVE FULLY READ THESE INSTRUCTIONS!**

**Please pass these instructions on to the operator of this equipment.**

# Table of Contents

<b>INTRODUCTION</b>	Page 3
<b>PREPARING YOUR SYSTEM</b>	Page 4
Choosing a Site	Page 5
Power Connection	Page 5
Pipe Connections	Page 6
<b>PUMP CONTROLLERS</b>	– Torrium Page 7
	– RainBank Page 10
<b>PRE-TREATMENT – (FILTRATION)</b>	Page 13
<b>STERIFLO® – (DISINFECTION)</b>	Page 14
Lamp Installation	Page 16
Operation	Page 16
Maintenance	Page 17
Water Quality	Page 18
Lamp Fail Alarm	Page 18
<b>TROUBLE SHOOTING</b>	Page 19

# INTRODUCTION

Congratulations on your purchase of a high quality, award winning Aquashield MAX Ultra Violet water treatment system.

Aquashield MAX represents advances in safety and convenience of rainwater harvesting technology for commercial and large scale rainwater users. The range offers increased water treatment quality and safety - producing water that is biologically safe to drink, without the use of chemicals.

This all in one unit is pre fitted with a correctly matched pump, Filterpure® and Steriflo® units and can come with either the Rainbank® Mk11 or the Torrium® pump controller.

The huge advantage of the Aquashield MAX pre engineered pack is that Davey do all the work and all thinking for you. Advantages like the pump interlocking and lamp count down timer ensures only correctly disinfected water is delivered.

## **Applications: Pressure boosting and disinfection of rainwater for:**

- School shower and toilet blocks
- Commercial toilet flushing
- Large home potable water supply
- Industry process water treatment
- Guest house potable water supply
- Bacteria and algae growth control for aquaculture and water features
- Also suitable for bore and surface water treatment – \*subject to a water quality test

## **Features & Benefits:**

- Factory matched and tested package – ensures correct UV dosage and high reliability
- Pump interlock detects lamp failure and locks pump out– ensures only disinfected water is delivered
- Lamp count down timer with set limit of 9000 hours - ensures only disinfected water is delivered
- Durable UV resistant cover – allows for flexible, vandal resistant exterior installation
- RainBank® MK II controller options – provides seamless automatic mains water backup
- Torrium® controller options – intelligent automatic pump control maximizes pump efficiency by adjusting run on time and cut in pressures
- 2 x 20” Jumbo cartridge filter housings – for low friction losses and long cleaning intervals
- 20 micron filtration – for long cleaning intervals and dirt, rust, sediment and debris reduction
- 1 micron filtration – for parasitic cyst reduction and high UV dosage rates

# PREPARING YOUR SYSTEM

Your new Aquashield MAX system incorporates a lamp failure system design feature that enables you to be warned of a lamp failure by :-

1. A lamp failure LED
2. An audible alarm
3. Remote alarm contacts
4. Pump lock out feature

In addition when the alarm “beeps” on and off, the lamp is due to be changed so effective treatment is maintained.



**Before installing your new Aquashield MAX please read all instructions carefully as failures caused by incorrect installation or operation are not covered by the guarantee. Your Ultra Violet water treatment system is designed to handle clean water. The system should not be used for any other purpose without specific referral to Davey Water Products. The use of the system with flammable, corrosive and other materials of a hazardous nature is specifically excluded.**



**DO NOT DISASSEMBLE ANY COMPONENTS UNTIL YOU HAVE FULLY READ THESE INSTRUCTIONS!**

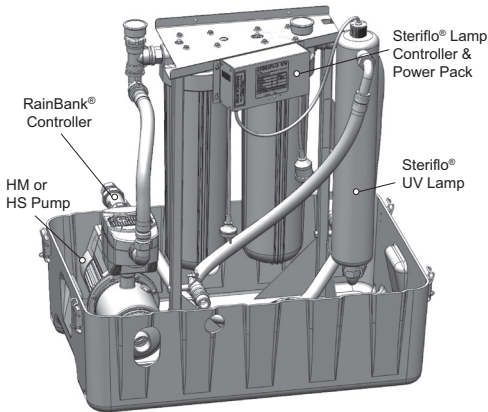

Aquashield MAX  
with RainBank®

Aquashield MAX  
with Torrium®

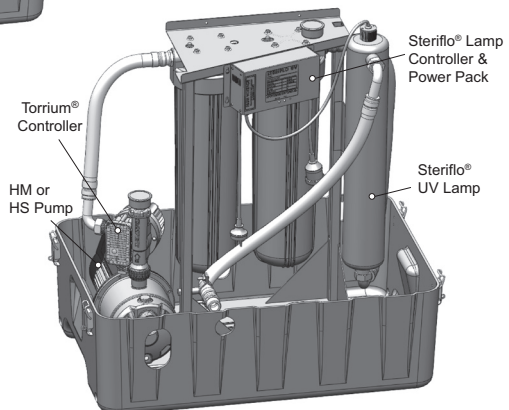

## Prior to using this system you must ensure that:

- The system is installed in a safe and dry environment
- The system enclosure has adequate drainage in the event of leakage
- Any transport plugs are removed
- The pipe-work is correctly sealed and supported
- The pump is primed correctly
- The power supply is correctly connected
- All steps have been taken for safe operation

## CHOOSING A SITE

Choose a site with a firm mounting position. Allow room for removal of the lamp and sleeve during servicing. Leave a chamber lengths space above the lamp cover & connector end for lamp removal.

To protect your system from the weather, make sure the site is flood proof, water proof, frost free and has adequate ventilation. Allow for drainage, to avoid damage to flooding etc., that over time may occur from leaking pipe joints or seals.



**WARNING:** Some insects, such as small ants, find electrical devices attractive for various reasons. If your site or enclosure is susceptible to insect infestation you should implement a suitable pest control plan.

## POWER CONNECTION



**WARNING:** When servicing or attending your Aquashield MAX, always ensure power is switched off and lead unplugged. Electrical connections should be serviced only by qualified persons. If the electrical supply lead of this system is damaged, it must only be replaced by a qualified service personnel.

Connect lead to power supply designated on control box label. Check that the earth is connected to the stainless steel chambers using bolt provided on the chamber.



The Steriflo® control box has a red LED alarm indicator light mounted on its front panel, adjacent to the amber “power on” LED. This light will be illuminated whenever the Steriflo® control box senses no lamp current. There is also an audible alarm in the event of lamp failure. The LED and/or alarm will only work when unit is connected to the correct electrical supply.



### NOTE:

- a) For protection, the Davey® pump motor is fitted with an automatic “over temperature” cut-out. Constant tripping of this overload device indicates a problem e.g. low voltage at pump, excessive ambient temperature (above 50°C) in pump enclosure.
- b) The Torrium® control device may have to be reset after rectifying any of the above operating troubles. This is done by pushing in the “prime” button and releasing it after 2 seconds, or switching the power supply off then on.



This appliance is not intended for use by persons (including children) with reduced physical, sensory or mental capabilities, or lack of experience and knowledge, unless they have been given supervision or instruction concerning use of the appliance by a person responsible for their safety.

# PIPE CONNECTIONS



**NOTE:** Prior to installation remove the transport plugs from the inlet, outlet and lamp end cap.

For best performance use P.V.C. or polythene pipes at least the same diameter as the pump's inlet and delivery outlet openings. Larger diameter pipe may be used to minimise resistance to flow when pumping longer distances.

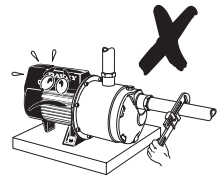
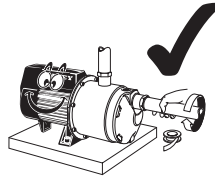

**Do not use pipe thread sealing compounds on any part of this pump. ONLY use Teflon sealing tape.**

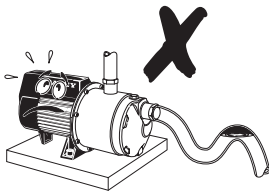

Use unions at pipe connections to enable easy removal and servicing. Use sufficient tape to ensure airtight seal and hand tighten only. To prevent strain on pump threads always support heavy inlet and outlet pipes. If there is a likelihood the water supply may contain solid particles such as pieces of plant or vegetable

matter, a filter should be installed before the pump to avoid blocking of water ways. Lay suction pipe at a constant gradient to avoid air pockets which may reduce pump efficiency.



**NOTE:** Suction leaks are the largest cause of poor pump performance and are difficult to detect. Ensure all connections are completely sealed using thread tape only.



**Do not use pipe thread sealing compounds (especially hemp) on any part of this unit. ONLY use Teflon sealing tape.**

Use unions at pipe connections to enable easy removal and servicing. Use sufficient tape to ensure airtight seal and do not over tighten. To prevent strain on unit threads always support heavy inlet and outlet pipes.



**RainBank® controllers can only be connected to mains water, by a qualified licensed plumber.**

# PUMP CONTROLLERS

## TORRIUM®

Your new system incorporates 'Torrium®', electronic flow controller – a Davey designed unit that enables the use of a highly efficient pump design and offers the following benefits:–

1. Enables the pump to deliver a constant flow of water particularly at low flow rates – reducing the inconvenience of pressure variation in showers etc.
2. Provides automatic “cut-out” protection should the pump run out of water or overheat\*, should the pump fail to start due to low voltage or a blockage in the pump.
3. Provides warning indications for critical and noncritical system faults.
4. Has adaptive pressure cut-in which allows the pump to start at approximately 80% of the maximum pressure at last shut-down. This allows the controller to accommodate varying inlet pressures and pump performance.
5. Automatic retry functions in the event of a critical system fault.

\* Motor overload / overheat protection included. Motor has its own overload / overheat protection.



The Davey Torrium® fitted to this pump has a **status indicator light** mounted on its front panel. This light will be illuminated whenever the Torrium® senses that there is electrical power available. The light will only work when unit is connected to the correct electrical supply.



The electrical connections and checks must be made by a qualified electrician and comply with applicable local standards.

## Status Indicator

The Torrium® has a status indicator light on the front panel. This light will enable you to understand what your pump is doing.

Condition	Indicator readout	Pump operation	Restart / Reset Method
Standby mode	Red light	Standby	Pressure drop
Running	Green light	Running	N/A
Cistern fill	Yellow/Amber light	Running - 2 minutes minimum run time	Auto, push "Prime" button or cycle power off / on
Loss of Prime	Red light single flash	Stops, auto-retry & "water return" activated	Push "Prime" button or cycle power off / on
Locked rotor or 'Prime' button held in too long	Red light double flash	Stops	See Trouble shooting guide
Under voltage	Red light double flash	Normal operation	Wait till voltage >180 volts or push "Prime" button or cycle power off / on
Water over temperature	Red light triple flash	Stops	Wait till water temp < 60°C
Slow leak	Red light triple flash	Normal operation with reduced cut-in pressure	Auto-reset or push "Prime" button or cycle power off / on



Only one fault condition will be indicated at once.

Both the Red & Green Indicators are shown in the same window. It is possible for the pump to be running (ie. Green indicator) and for a Red flash sequence to happen at the same time. In that case the Red flash will show as a Yellow or Amber flash.

## Cistern Fill Mode

When your new HP or HS pressure system is used to fill toilet cisterns or troughs, a special feature of the Torrium® controller may be activated. This special feature is activated when the controller detects three quick stop start sequences in a short period. When activated the status indicator will glow “Amber”, and the pump will run on for two minutes before shutting down. This allows the cistern to be filled with the minimum number of pump cycles.

## Electrical Power Surge Protection

An electrical power surge or spike can travel on the supply lines and cause serious damage to your electrical equipment. The Steriflo® control box has a 2 Amp fuse to protect the circuit. The fuse is not a lightning arrestor and may not protect the Steriflo® if lightning or a very powerful surge hits the unit.

If the installation is subject to electrical power surges or lightning we strongly recommend the use of suitable additional surge protection devices on ALL electrical equipment.

**We recommend the use of an RCD or earth leakage circuit breaker on the power supply to your unit.**



Ultra violet radiation is harmful to skin & eyes.  
DO NOT LOOK AT UV LAMP WHILE LAMP IS OPERATING.



**DO NOT DISASSEMBLE ANY COMPONENTS UNTIL YOU HAVE FULLY READ THESE INSTRUCTIONS!**

## Auto-retry and Water Return Modes

Should your Torrium® detect a loss of prime, after stopping the pump, it will wait five minutes before activating Auto-retry and Water Return modes. Auto-retry automatically starts the pump to see if the pump is now primed. It does this after 5 mins, 30 mins, 1 hr, 2 hrs, 8 hrs, 16 hrs and 32 hrs. Water return mode will restart the pump automatically if the Torrium® detects water flow through it.



**NOTE:** If multiple errors are present, the highest priority error (least number of flashes) is indicated. Any previous fault code is lost until it recurs.

## Priming and Operation

The Torrium® module fitted to your HM or HS system is provided with a push button “Prime” button. This button is used during initial priming of the pump and also acts as a reset button if the Torrium® switches out in pump protection mode.

1. Remove priming plug and fill casing and suction line (on flooded suction, simply open gate valve to pump). When full, replace priming plug.

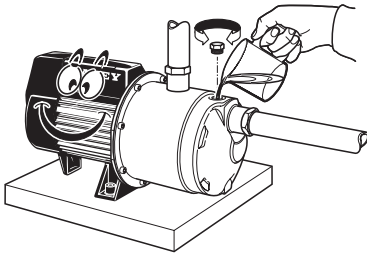

2. Ensure outlet nearest to pump is open.



3. Ensure all valves in suction line are open.

4. Switch on power - The status indicator light will be illuminated green and the pump will run. A full flow of water should be discharged from the open tap.

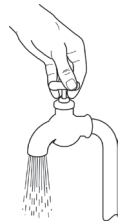

5. If the pump stops with the tap open see troubleshooting checklist.
6. Close the open outlet or tap and the pump should stop after a few seconds (the status indicator light should be illuminated red (constant). If not, consult the troubleshooting checklist.

### To Reset if Pump switches out in Pump Protection Mode

1. Make sure pump is primed.
2. Open tap, push prime button.
3. Close tap and pump will stop.

## RAINBANK® – HOW IT WORKS

1. When there is demand for water from your toilet, washing machine or garden tap RainBank® senses this demand and checks the level of water in the rainwater tank. Note: demand must be greater than 1.5 litres per minute or mains water will be delivered.
2. If there is rainwater in the tank RainBank® switches on the pump. The pressure of the pump is sufficient to overcome the pressure of the mains water inside RainBank® and this closes a dual check valve and allows the rainwater to flow. Note: mains water pressure is limited to 300kPa.
3. When there is no longer a demand for water, RainBank® detects that water has ceased to move inside the pipes, switches off the pump and waits for another water demand.
4. If RainBank® senses a water demand and detects insufficient water in the rainwater tank it will automatically allow the mains water to flow.
5. If there is a power failure during a demand for water RainBank® will automatically supply the mains water as backup.

## Fit float switch to rainwater tank

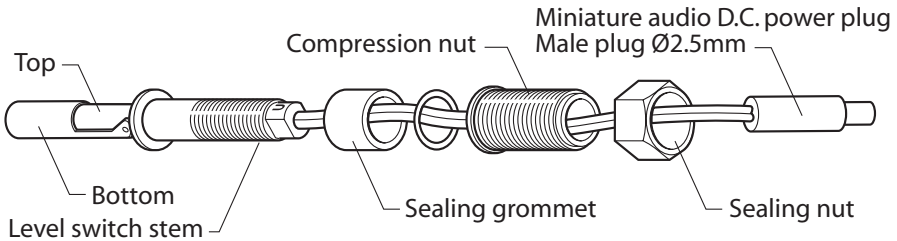

### **IMPORTANT**

- The level switch is suitable for installation in polyethylene and fibreglass tanks. It can be fitted in steel tanks but cutting through the zinc alum or colourbond coating of the tank exposes bare steel and this can rust. Check with the tank manufacturer before drilling.
- The float switch is designed to be installed from the outside of the tank. There is no need to get inside the tank.
- The sealing grommet of the float switch is designed to work in a maximum tank wall thickness of 25mm. It is not suitable for concrete or very thick plastic walled tanks. There is an alternative float switch that can be lowered into the top of these types of tanks (Davey Part Number 13449).

Work out the correct position for the hole for the float switch. With a corrugated profile tank wall this is on the upper flat section of the profile as shown below.

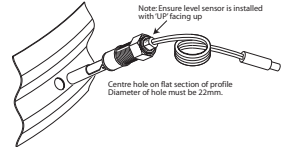

Work out the correct location of the float switch relative to the pump outlet.

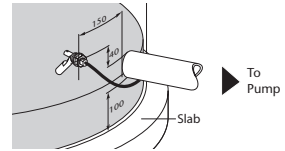

The float switch location should also be:

- At least 40mm above the pump inlet.
- Placed away from the rainwater entry into the tank so that the incoming flow does not interfere with the operation of the switch.

Before cutting the hole check again that the 5m lead from the float switch will reach the RainBank® and plug comfortably into it.

1. Drill a 22mm hole in the side of the tank in the correct position. A hole saw is the best tool for this job. Ensure all swarf is removed from the hole. If installing the switch in a corrugated tank you should make sure that it is installed on the flat section between the radii as shown below.

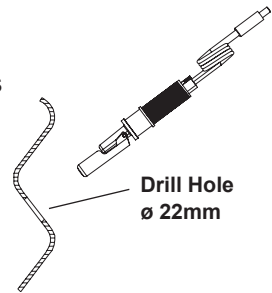

2. Ensure the compression nut is loosened so that the sealing grommet is not expanded. Remove the sealing nut and insert the switch into the hole as below.

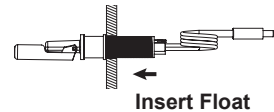

3. The switch will not work properly if it is not properly orientated. Make sure the word "UP" is seen at the very end of the switch body. Now tighten the compression nut to expand the seal (as shown below).



4. Ensure that the switch is still correctly orientated. With the word "UP" visible, screw on and tighten the sealing nut to finish the installation of the float switch.

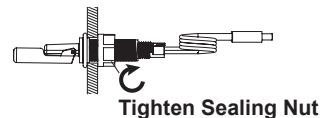



**IMPORTANT:** To allow easy connection it is strongly recommended that you have flexible copper pipes that allow some movement so that they can line up exactly with the mains water and rainwater outlet. These pipes must be 3/4 inch in diameter.



**IMPORTANT:** It is highly recommended that an isolation valve be fitted to where the mains water enters RainBank® and between the pump and the rainwater tank. This facilitates easy removal of the unit if required without turning off the household water or losing stored rainwater.

Test the operation of RainBank®.

1. With the mains connected and the rainwater tank empty turn on one of the taps in the laundry that feed the washing machine or flush the toilet. Mains water should flow normally. The pump should not turn on. When this is completed turn off tap.
2. Fill the rainwater tank with sufficient water to activate or cover the float switch.
3. Check that the pump is correctly primed and there are no air locks that will interfere with its operation as per the Davey instructions. This is essential for the proper operation of the unit. See the instructions on how to do this for all types of Davey pump in the Priming section on page 26.
4. Turn on a tap or flush a toilet in the rainwater system. The pump should run and deliver rainwater. Allow to run for several minutes to clear air from pipes.
5. Remove the float switch connection from the RainBank® – this should stop the pump and confirms that the float switch and power connections have been made correctly - refit the float switch connection. Press the manual override button to operate the pump if needed.
6. Check for leaks around RainBank®, the pump, pipework and fittings.

## PRE-TREATMENT (FILTRATION)

Prefiltration is usually required to ensure that particulate matter does not shield micro-organisms from the UV light. Sand filtration or 20 micron cartridge filtration is the usual minimum, this is provided in Stage 1 filtration. In some cases, particularly with surface water, finer filtration may be necessary, or if cysts like Giardia or Cryptosporidium may be present. In this case 1 micron filtration is required, as provided in Stage 2 filtration.

### Temperature Rating

Maximum 50°C - Minimum 8°C



**Caution:** The housing must be protected against freezing. Failure to do so may result in cracking of the housing and water leakage.



**WARNING:** CAREFULLY AND GENTLY TIGHTEN WITH HOUSING SPANNER as the bowl should only be tightened enough to avoid water leaking during operation.



**WARNING:** If the water system is not going to be used for extended periods, the cartridge should be removed from the housing and replaced with a new or cleaned cartridge when the system is used again.

### Sediment Cartridge Filter Life

Once the housing is properly installed, a reduction in flow/pressure (to such an extent as to cause inconvenience) will indicate when the cartridge is becoming clogged and needs replacing/cleaning. Sediment cartridges should be replaced/cleaned/sanitised when the water flow has been noticeably reduced/or after 3-6 months - whichever comes first (this is for hygiene reasons).



**NOTE:** Actual filtration/purification life of cartridge can vary with the condition of incoming water.



**NOTE:** Clean filter Stage 1 once a pressure drop of 100 to 150kPa from clean, or between Stages 1 and 2.

### Changing the Filter Cartridge

1. Turn off the valve to stop the flow of water.
2. Release the pressure by opening a tap downstream, or use the pressure relief valve that is available in the lid of some filter housings.
3. Unscrew the bottom housing from the lid and pull out the used cartridge and discard or wash. The inside of the filter housing and the lid should be checked for cleanliness - they will usually need to be cleaned or sanitised - use hot water and dishwashing liquid, thoroughly scrub all surfaces and then rinse.
4. Check that the ring is in position in the top of the housing base, lubricate with a coating of white petroleum jelly (Vaseline), place the

oring into the groove and with two fingers wipe the oring down into the groove. Do not wipe the oring clean of lubricant after it has been properly seated in the groove because the lubricant prevents “crawling” of the oring during the tightening of the lid and thus prevents water leaks.

5. Screw the housing onto the lid and hand tighten. Open the tap downstream of the filter and then open the inlet valve.



**IMPORTANT:** When opening the filter housing to install or change the cartridge (element) it is common for the oring seal to lift out of the groove and, at times, it may even stick to the cap.



**CAUTION WHEN INSTALLING**

1. This is a plastic product with a female thread. If you cross-thread a male fitting, and/or you over pack with sealing tape, you could do permanent damage.
2. If you use a tapered thread male fitting do not over tighten.
3. No warranty claims will be considered for damage due to incorrect installation.

## STERIFLO®

Your new Steriflo® system incorporates a lamp failure system design feature that enables you to be warned of a lamp failure by :-

1. A lamp failure LED
2. An audible alarm
3. Remote alarm contacts

In addition when the alarm “beeps” on and off, the lamp is due to be changed so that effective treatment is maintained.

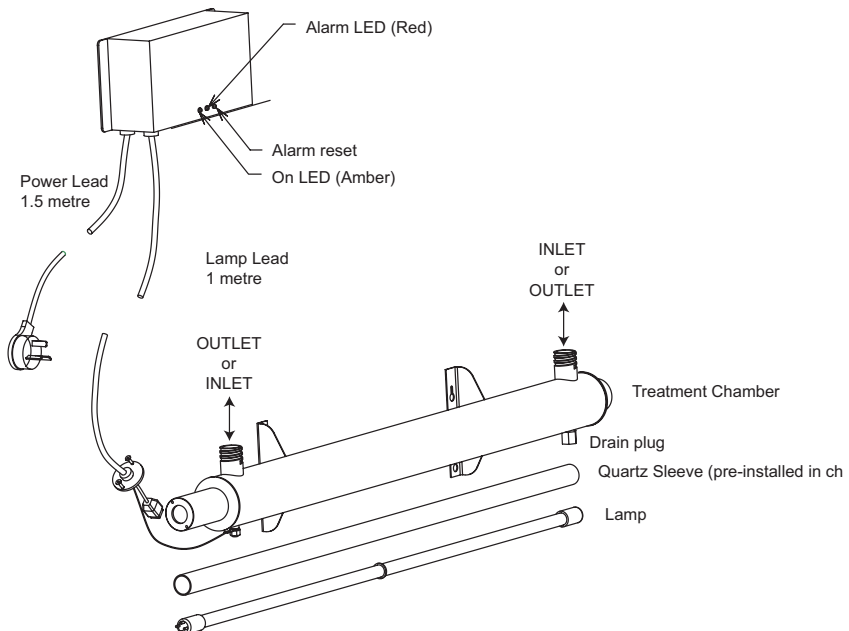



The appliance is not intended for use by young children or infirm persons without supervision. Young children should be supervised to ensure they do not play with the appliance



**NOTE:** The quartz sleeve has been factory fitted, and there is no need to remove these endcaps on first installation. Before removing endcaps, please read the Maintenance section of these instructions completely.

## PREPARING YOUR SYSTEM

On removing your Steriflo® system from its carton you should check all components, especially the lamp, to ensure all are present and have not been damaged in transportation. You should have:

1. Power supply control box with indicator light(s) and electrical flex.
2. UV lamp (or lamps).
3. Treatment chamber with mounting brackets.

Connect lead to power supply designated on control box label. Check that the earth is connected to the stainless steel chambers using bolt provided on the chamber.



Install the power supply enclosure above the treatment chamber so that in the event of a leak, water cannot drip down the lamp lead into the enclosure. **CAUTION:** The supply cord is necessary for lamp changing. The three pin supply plug must remain accessible after installation. If installed to fixed wiring without the plug a two pole switch must be fitted and its ON and OFF positions shall be marked.



The Steriflo® control box has a red LED alarm indicator light mounted on its front panel, adjacent to the amber "power on" LED. This light will be illuminated whenever the Steriflo® control box senses no lamp current. There is also an audible alarm in the event of lamp failure. The LED and/or alarm will only work when unit is connected to the correct electrical supply.

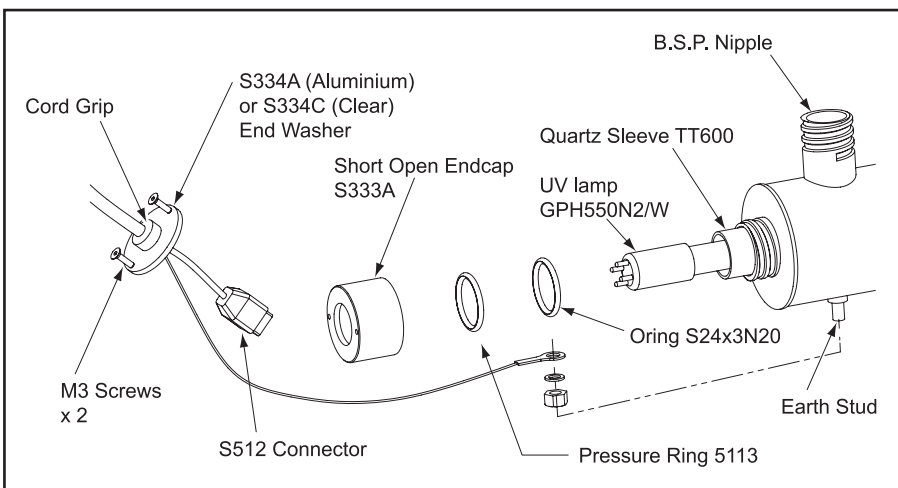

## LAMP INSTALLATION

Once the Steriflo® Treatment Chamber has been connected to the pipework, the installation should be checked for water leaks.

Attach the “DO NOT LOOK AT LAMP” sticker in an obvious position on the treatment chamber, check that the chamber is clean to ensure the sticker will adhere correctly.

The Quartz Sleeve is pre-installed in the treatment chamber, and provided the endcaps have not been disturbed or undone, is able to withstand well in excess of the maximum operating pressures.

If the chamber test is successful, it is now time to insert the lamp. **DO NOT INSERT THREE PIN POWER PLUG TO POWER OUTLET YET!**

Expose the connection end of the lamp from its transport tube and protective wrapping. The lamp connection socket is “keyed” to ensure correct alignment. Carefully remove the tube fully from its transport tube, touching the lamp as little as possible. Handle the lamp by the ends where possible. Wipe with clean cloth and methylated spirits if fingerprints or dirt need removing.

Slide the lamp into the chamber, fit lamp connection socket and then fasten the end washer into the endcap, with the screws provided.

## OPERATION

Once all leak testing and lamp fitment has been completed, open valves and allow water to fill the chamber. Connect three pin plug to outlet and switch on. The “Mains On” Amber LED will be illuminated and the red alarm light will flash slowly.

Allow two minutes for the UV lamp to reach full intensity before starting water flow.

Full lamp performance for a new installation will be achieved in 24 hours. On a new installation where no other form of sterilisation has been in constant usage, we recommend flushing the pipework with a suitable sanitiser such as Steritank HP at 100mg/L. This solution should be left in the piping for at least an hour and preferably overnight.

The Steritank solution can be dosed to the water tank or if necessary added as a shot dose to the bowl of any filter housing installed with the UV system and slowly flushed into the piping.

If dosed to the water tank the Steritank HP will be left in the water as it is tasteless and suitable for use in drinking water. If added as a shot dose it should be rinsed out through a nearby tap.

**Davey Water Products Limited can not accept responsibility for loss or damage resulting from incorrect or unauthorised installations.**

# MAINTENANCE

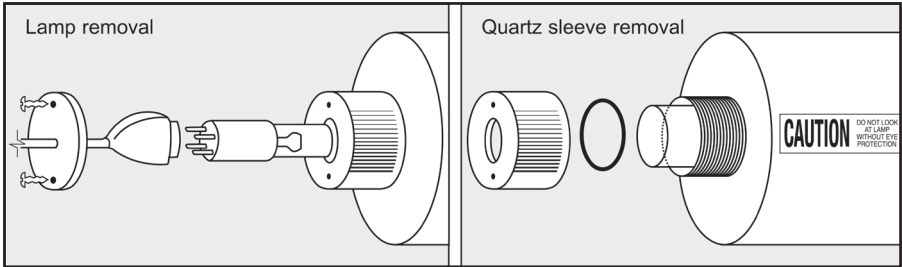

## Lamp changing (every year of operation) :

1. Shut valve(s) so that water cannot flow through steriliser.
2. Switch off steriliser by unplugging mains.
3. Undo end cover screws.
4. Unplug lamp connector.
5. Remove lamp.

Reverse procedure when replacing lamp, ensuring that lamp is centrally located in the chamber. Handle only by the ends.

## Quartz Sleeve Cleaning :

If dirt is allowed to build up on the quartz sleeve it will impair the UV output. The quartz sleeve should be removed after one month and inspected for deposits. Clean with methylated spirits (5% hydrochloric acid if heavily fouled) and carefully dry. Handle the sleeve with tissue to keep it clean. The sleeve should be cleaned every three months or as required.

## Sleeve removal (use care-fragile) :



**CAUTION: Handling lamp and quartz sleeve. Keep the quartz components free of finger marks to avoid loss of output through dirt or grease shadows - handle the lamps by their ends where possible. Wipe lamp and sleeve with clean cloth or tissue if needed. The o-rings should be replaced annually or if damaged – do not grease the o-rings.**

1. Remove lamp as described.
2. Remove drain port cap and empty water from chamber.
3. Undo nut at one end of the chamber and remove o-ring, repeat with nut at other end and remove o-ring, withdraw sleeve carefully.



**NOTE: When withdrawing sleeve take care not to let the end drop into the chamber as it could break - a clean dowel inserted right through the sleeve to support it is useful.**

4. Inspect o-rings for damage, replace annually.

## **MAINTENANCE CONTINUED...**

Reverse procedure when replacing sleeve.

When replacing quartz sleeve after cleaning, the sleeve should stick out about 1cm at each end. Place o-ring over closed nut end and fit closed nut, fastening it hand tight. Hold the other end of the sleeve in position during the tightening with the other hand, then fit open end o-ring and cap.

A tiny amount of silicon spray or CRC in the end of aluminium endcap threads will aid easy tightening. Do not use excessive force when tightening nuts. Do not re-use quartz sleeve or o-rings if damaged.

## **WATER QUALITY**

Where the water being pumped contains unusually high levels of dissolved solids (hard water), iron, manganese or biological organisms, a deposit build up on the quartz sleeve may occur over time. This will compromise the effectiveness of the UV system and the sleeve should be cleaned as required to maintain it in a clean condition. Discoloured water will reduce the effectiveness of the UV system and filtration should be installed.

## **LAMP ALARM SYSTEM**

If the UV lamp is out due to a failure or bad connection the alarm buzzer will sound and the red LED will light and the alarm will disconnect power from the pump preventing untreated water from being delivered. The alarm function can be checked by switching the unit off, disconnecting the lamp and then switching the unit back on.

The lamp should be replaced after a year's running time. The alarm will beep intermittently after the internal clock has measured this time as a reminder to change the lamp. Pressing the recessed 'reset' button with a ballpoint pen will silence it for 24 hours at a time to allow time for a new lamp to be obtained. Once a new lamp is installed press the reset button for 5 seconds to start another year's timing. Do this whenever a new lamp is installed. The alarm light flashes slowly during normal operation to show the timer circuit is running.

# TROUBLESHOOTING

## TORRIUM®

- a) PUMP HAS STOPPED OR MOTOR RUNS FOR SHORT PERIOD ONLY WHEN SWITCHED ON OR PRIME BUTTON PUSHED, BUT DOES NOT PUMP - STATUS INDICATOR LIGHT ILLUMINATED RED FLASHING ONCE PER SEQUENCE
1. Suction line and pump body not filled with water.
  2. Air leaks in suction lines or suction pipe not under water.
  3. Air trapped in suction lines (also possible with flooded suction due to uneven rise in piping; eliminate humps and hollows).
  4. No water at source or water level too low.
  5. Valve on suction lines closed. Open valve & pump will restart automatically or press "Prime" button.
- b) PUMP SWITCHES ON AND OFF FREQUENTLY (CYCLING)
1. Cycling may occasionally be caused by float valves filling tanks - see "Cistern Fill Mode".
  2. Leaking taps, float valves etc. check plumbing.
  3. Leaking check valve/foot valve.
  4. Discharge plumbing has been connected to the priming port.
- c) MOTOR DOESN'T START WHEN SWITCHED ON - LOW PRESSURE INDICATOR LIGHT NOT ILLUMINATED
1. Power not connected or no power available from supply outlet.



**WARNING:** Automatic reset thermal overloads may allow the pump to restart without warning. Always disconnect the pump motor from the electrical supply before maintenance or repairs.



**WARNING:** When servicing or attending pump and/or controllers, always ensure power is switched off and lead unplugged. Electrical connections should be serviced only by qualified persons.

- d) MOTOR STOPS - STATUS INDICATOR LIGHT IS ILLUMINATED RED, FLASHING TWICE PER SEQUENCE
1. Motor "over temperature" cut-out tripped. Consult Davey dealer.
  2. Motor not free to turn - e.g. a jammed impeller. Consult Davey dealer.
  3. Prime button has been held in for too long. Release prime button and switch off power for 1 minute to allow unit to reset.
- e) PUMP WILL NOT STOP
1. Water leaks on discharge side of pump.

- f) PUMP WILL OPERATE NORMALLY INITIALLY BUT WILL NOT RESTART ON WATER DEMAND - STATUS INDICATOR LIGHT NOT ILLUMINATED
  - 1. Power supply problem - see c) 1.
- g) PUMP WILL OPERATE NORMALLY INITIALLY BUT WILL NOT RESTART ON WATER DEMAND - STATUS INDICATOR LIGHT IS ILLUMINATED RED CONSTANT
  - 1. Suction air leak - pump has partially lost prime.
  - 2. Blocked impellers or suction.
  - 3. Discharge valve closed - open valve.

## **RAINBANK®**

- a) PUMP WILL NOT SWITCH OFF
  - 1. Pump plugged directly into power outlet. Plug lead from pump into base of RainBank® as per installation instructions.
  - 2. Yellow 'manual override' button pushed in too far. Pry out the section of the yellow button that has been pushed into the RainBank® housing with a small flat blade screwdriver.
  - 3. Water is still being used. Check all taps, toilets and appliances connected to RainBank® system to ensure they are turned off.
  - 4. Water is leaking on discharge side of RainBank® system. Repair leak.
  - 5. Rock or debris caught inside RainBank®. Call your plumber to fit a Y strainer - RainBank® will need to be returned to Davey.
- b) PUMP WILL NOT SWITCH ON
  - 1. Pump not plugged in. Plug pump into base of RainBank® and RainBank® into power supply.
  - 2. No power supply to pump. Contact electrician and have power restored.
- b) PUMP WILL NOT SWITCH ON
  - 3. Float switch not connected to RainBank®. Plug float lead into base of RainBank®. The connection port is located next to the power lead coming from the RainBank®. To confirm the connection is correct, depress yellow button, pump will start.
  - 4. No water in tank. Check water level in tank.
  - 5. Float switch located at water tank is installed incorrectly. Check to see if the word "UP" is facing up on float switch.
  - 6. Mains water supply not connected to RainBank. RainBank® system must have a pressurised water supply connected to inlet. Press yellow "manual override" button to simulate mains water flowing.
  - 7. Mains supply to RainBank® turned off. Turn on mains water supply.
  - 8. Pump is faulty. To confirm if the fault is within the pump, plug the pump directly into power point and check to see if it starts. If the

pump starts plug the pump back into the RainBank® and continue fault finding. If the pump does not start contact your supplier for further advice.

9. Lead from float switch to pump broken or damaged. Replace float and lead assembly.
10. Float switch defective. Contact your supplier for further advice.

### c) OTHER SYMPTOMS

#### **Mains water is still in use when pump is running.**

Possible cause - pump needs to be primed. Remove priming plug from front top of pump (right above water inlet) and allow all air to escape from pump. Replace the priming plug when water dribbles out of hole.

#### **Mains water is still in use when pump is running.**

Possible cause - pump impeller blocked. Have pump serviced. Fit first flush devices and Y strainer to pipework.

#### **Mains water not passing through RainBank®.**

Possible cause - RainBank® installed backwards. Install RainBank® according to installation & operating instructions.

#### **Mains water not passing through RainBank®.**

Possible cause - debris is blocking inlet to RainBank®. Remove RainBank® and clean inlet.

#### **Pump hums.**

Possible cause - pump is jammed or seized. Have pump serviced.

#### **Water leaking from drain holes in RainBank®.**

Possible cause - installer has not held fitting when connecting pipes to RainBank® and has damaged internal connections. Replace RainBank®.

#### **Water leaking from connection between pump and RainBank®.**

Possible cause - connection kit is not tight. Remove RainBank® and re-install connection kit.

#### **Water leaking from connection between pump and RainBank®.**

Possible cause - installer has failed to fit connection kit correctly. Remove RainBank® and re-install connection kit.

#### **Float switch pops out of tank.**

Possible cause - hole in tank is too large. Installer to drill correct size hole or fit float switch adaptor Part number 13708SP.

# STERIFLO®

Principle. A ballast (choke) provides the correct voltage and current for the lamp(s). The circuit board monitors the current to the lamp and if it is not present, illuminates the red alarm light and sounds the alarm buzzer (a “squealing” noise). An orange light indicates the power is on.

- a) UV LAMP OUT, NO ORANGE “ON” LIGHT, NO ALARM
  - 1. No mains voltage.
  - 2. Internal fuse failed.
  - 3. Check mains power connections inside power supply.
- b) UV LAMP FLICKERING, ALARM ON
  - 1. Failed lamp.
  - 2. Incorrect lamp or ballast fitted.
- c) UV LAMP OUT, ALARM ON
  - 1. Lamp failed.
  - 2. Poor connection to lamp (check/clean connector/lamp pins).
  - 3. Ballast failed (unlikely).
- d) LAMP ON, ALARM ON
  - 1. Faulty circuit board.
- e) LAMP OUT, ALARM OFF
  - 1. Loose connection or faulty circuit board, possibly short in lamp circuit.



**WARNING: When servicing or attending your Steriflo®, always ensure power is switched off and lead unplugged. Electrical connections should be serviced only by qualified persons. If the supply cord is damaged, it must be replaced by the manufacturer, its service agent or similarly qualified persons in order to avoid a hazard.**



**Care should also be taken when servicing or disassembling the unit and associated pipework to avoid possible injury from pressurised water. Unplug power, relieve pressure by opening a tap on the discharge side of the unit and allow any water in the unit to cool before attempting to dismantle.**

## Part Numbers

- a) Lamp  
GPH550N2/W
- b) Sleeve  
TT600
- c) O-rings  
All models S24x3N70 (2 per sleeve)
- d) Lamp Connector  
All models S486



**WARNING**  
**ULTRA-VIOLET RADIATION IS HARMFUL TO SKIN AND EYES.**

**EYES**

Switch off UV system before removing covers. If working within line of sight of UV light, ensure that a suitable full face plastic facemask is worn.

**SKIN**

It is recommended that exposed skin is covered to prevent sunburn, possibly severe, if working within line of sight of operating UV system. Note: exposure to UV light results in symptoms that develop slowly, the exposure cannot be felt at the time.

**SYMPTOMS**

**EYES:** Mild exposure - irritation developing several hours later.  
Severe exposure - sore, red eyes, sensitive to light, painful to keep eyes open.

**SKIN:** Mild exposure - slight reddening, tenderness, mild sunburn symptoms.  
Severe exposure - skin sloughing (peeling), weeping area, severe sunburn symptoms.

**FIRST AID**

**EYES:** In mild cases, if in doubt seek medical attention.  
Severe cases cover eyes with gauze or clean cloth, seek medical attention.

**SKIN:** In mild cases removal from exposure may be sufficient. If in doubt seek medical attention.  
In severe cases, cover affected area loosely with a clean bandage or cloth. Seek medical attention. Do not apply fat, butter or oil to skin.

The above notes are intended to highlight the dangers of exposure to UV radiation. With sensible precautions any hazard can be eliminated. Germicidal UV cannot pass through clothing or other opaque materials or clear materials such as plastics or even window glass.



During service **DO NOT** use lubricants or sealants of any type on the o-rings. Keep the inside of the quartz sleeve dry and clean.



**WARNING** - Do not use hydrocarbon based or hydrocarbon propelled sprays around the electrical components of this unit.

## PRODUCT GUARANTEE (NEW ZEALAND)

Aquashield MAX systems, except for lamps, are guaranteed from the date of original purchase to be free of material or manufacturing defects. Should any part fail as a result of such defects within this period, the system will be repaired free of charge. The pumps, Torrium® and RainBank® are covered for 2 years. The Steriflo® lamp, controller and Filterpure® are covered for one year. Additionally, a one year pro-rata, parts only guarantee commencing from the date of original purchase shall apply only to the lamp.

### TERMS AND CONDITIONS

1. This guarantee applies to all states and territories of Australia and New Zealand only and is subject to the provisions of the Trade Practices Act (Aust.), the Goods and Consumer Protection Legislation of the various Australian states and the Consumers Guarantee Act 1993 (NZ) as applicable.
2. The guarantee period commences on the date of original purchase of the equipment. Evidence of this date of original purchase must be provided when claiming repairs under guarantee. It is recommended you retain all receipts in a safe place.
3. This guarantee covers parts and workshop labour only. Goods should be forwarded, with proof of date of original purchase, to an Authorised Davey Service Centre in Australia or Davey Water Products Limited in New Zealand, freight paid.
4. The pro-rata lamp guarantee is calculated on a monthly basis, up to 12 months.
5. This guarantee is subject to due compliance by the original purchaser with all directions and conditions set out in the Installation and Operating Instructions. Failure to comply with these instructions, damage or breakdown caused by fair wear and tear, negligence, misuse, incorrect installation, chemical or additives in the water, inadequate protection against freezing, rain or other adverse weather conditions, corrosive or abrasive water, lightning or high voltage spikes or through unauthorised persons attempting repairs are not covered under guarantee. The product must only be connected to the voltage shown on the nameplate.
6. Without limiting the original purchaser's entitlements under the Trade Practices Act (Aust.), the Goods & Consumer Protection Legislation of the various Australian states, or the Consumers Guarantee Act 1993 (NZ), Davey shall not be liable for any loss of profits or any consequential, indirect or special loss, damage or injury of any kind whatsoever arising directly or indirectly from the product or any defect.
7. Where the Trade Practices Act (Aust.), the Goods and Consumer Protection Legislation of the various Australian states and the Consumers Guarantee Act 1993 (NZ) does not apply, Davey shall not be liable for any loss of profits or any consequential, indirect or special loss, damage or injury of any kind whatsoever suffered by the purchaser arising directly or indirectly from the product or any defect and the purchaser shall indemnify Davey against any claim by any other person whatsoever in respect of any such loss, damage or injury.
8. Nothing in this guarantee is intended to have the effect of contracting out of the provisions of the Trade Practices Act (Aust.), the Goods and Consumer Protection Legislation of the various Australian states and Consumers Guarantee Act 1993 (NZ) except to the extent permitted by the various Acts and this guarantee is to be modified to the extent necessary to give effect to that intention.
9. Davey may be collecting personal information from you in order to provide you with a service. Davey Water Products Pty Ltd promises only to use this information in accordance with the Provisions of the Privacy Act 1988 (Cth) and the Privacy Policy of Davey Water Products Pty Ltd which is available at [davey.com.au](http://davey.com.au).

® Davey, Filterpure, RainBank, Steriflo & Torrium are registered trademarks of Davey Water Products Pty Ltd.  
© Davey Water Products Pty Ltd 2008.

## Davey Water Products Pty Ltd

Member of the GUD Group

ABN 18 066 327 517

### Head Office and Manufacturing

6 Lakeview Drive,  
Scoresby, Australia 3179  
Ph: +61 3 9730 9222  
Fax: +61 3 9753 4100  
Website: [davey.com.au](http://davey.com.au)

### Customer Service Centre

Ph: 1300 367 866  
Fax: 1300 369 119  
E-mail: [sales@davey.com.au](mailto:sales@davey.com.au)

### Interstate Offices

Sydney • Brisbane • Adelaide  
Perth • Townsville

### International

6 Lakeview Drive,  
Scoresby, Australia 3179  
Ph: +61 3 9730 9121  
Fax: +61 3 9753 4248  
E-mail: [export@davey.com.au](mailto:export@davey.com.au)

### Germany

Kantstrasse 53, 04275 Leipzig  
Ph: +49 341 301 0412  
Fax: +49 341 301 0413  
E-mail: [akrenz@daveyeurope.com](mailto:akrenz@daveyeurope.com)

### USA

Ph: +1 630 898 6976  
Website: [daveyusa.com](http://daveyusa.com)  
E-mail: [sales@daveyusa.com](mailto:sales@daveyusa.com)

### Davey Water Products New Zealand

7 Rockridge Avenue,  
Penrose, Auckland 1061  
Ph: +64 9 570 9135  
Fax: +64 9 527 7654  
Website: [daveynz.co.nz](http://daveynz.co.nz)  
E-mail: [sales@daveynz.co.nz](mailto:sales@daveynz.co.nz)

### Davey Spa – New Zealand

2 Rothwell Avenue,  
North Harbour, Auckland 0632  
Ph: +64 9 415 8622  
Fax: +64 9 415 8621  
Website: [spa-quip.co.nz](http://spa-quip.co.nz)  
E-mail: [service@spa-quip.co.nz](mailto:service@spa-quip.co.nz)