

INSTALLATION AND OPERATING INSTRUCTIONS

DEEP WELL INJECTOR KITS FOR USE WITH

ENGINE DRIVEN FIREFIGHTING PUMPS

1. INTRODUCTION

These instructions apply to Jet Kits:-
 29429 Suits 4" Body
 29468 Suits 4" Body
 29569 Suits 5" Body
 used in combination with injector bodies
 23300 Suits 4" Body
 23301 Suits 5" Body

2. PRINCIPLE OF OPERATION

The engine driven firefighter pump is positioned alongside or closely offset from the bore. During operation some of the flow produced by the pump is directed back down the bore and into an injector body, housing a jet and venturi. The flow from the pump produces a region of low pressure in front of the jet which draws water in from the bore via the foot valve on the injector body. The combined flows are then fired up the bore to the surface pump. Usable flow/pressure is available at one of the 1" outlets on the pump discharge. A minimum pump casing pressure is required for each jet/venturi combination to ensure the system does not lose prime. This and the discharge pressure from the pump can be monitored via a pressure gauge fitted into the priming plug.

3. KIT CONTENTS

The Deep Well Kit supplied by Davey consists of an injector body, a pressure pipe end connector, a foot valve a foot valve connecting nipple (5" injector only), thread tape, a separately boxed jet and venturi kit, Installation and Operating Instructions. All other fittings can be supplied by your local Davey Dealer who will be happy to assist.

4. PLUMBING DETAILS

- A) Prior to connecting the fittings to the pump, to assist priming, the flap valve (non return valve) on the 1 1/2" inlet of the pump should be removed. Alternatively a tee installed at the top of the pressure and suction pipes may be used to add water at this point, provided that both tees are sealed and air tight. The pump must also be full of water before pump operation.
- B) A minimum submergence of 3 metres (10ft) is required for the injector and foot valve assembly for correct operation - see diagram.
- C) When water is pumped out from a borehole, it is common for the water level in the bore to drop. However there is usually a point at which the bore water remains static or constant for a given maximum flow from the bore. This new level is known as the "draw down" level of the bore. It is necessary to establish this draw down level and the output capacity of the bore at this level before installing a pump on the bore.

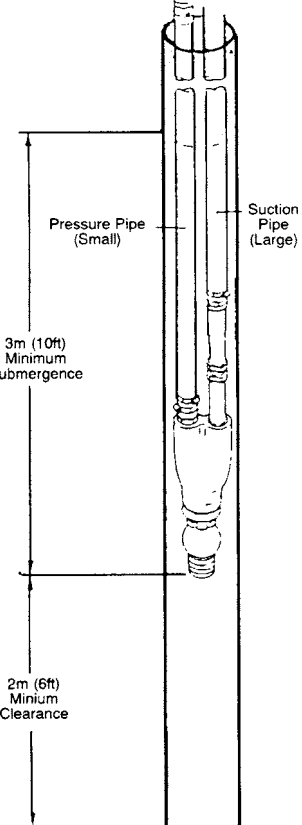

- D) Once the pump has been installed on the bore, it is necessary to regulate the flow from the pump to ensure it does not exceed the maximum capacity of the bore at the draw down level.
- E) The length of piping required from top of bore to injector assembly is equal to the draw down level plus 3 metres (10ft).
- F) Ensure at least 2 metres (6ft) clearance exists between the injector assembly and the bottom of the bore.

5. INJECTOR AND PIPEWORK ASSEMBLY

- A) INJECTOR
 - i) Secure the brass injector body in a vice with the two threaded holes facing up.
 - ii) Apply thread sealant (tape supplied) to the male thread on the venturi.
 - iii) Fit jet to female threaded hole inside injector body. Use a 13/16" tube (automotive spark plug) spanner.
 - iv) Fit long venturi to outer threaded hole directly above jet.

NOTE: Firm hand tightness only is required when fitting jet and venturi. Do not over tighten.

- v) Fit Poly connector to threaded hole on outer side of injector body using thread sealant.
- vi) Fit foot valve to base of injector body.

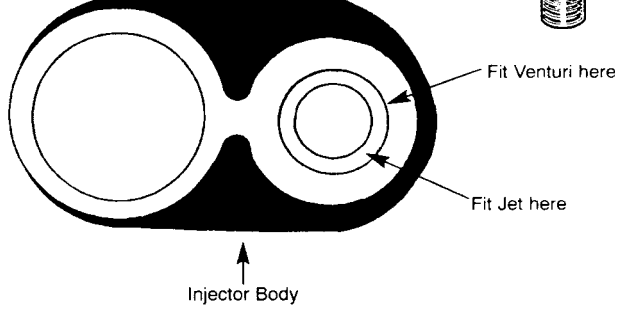
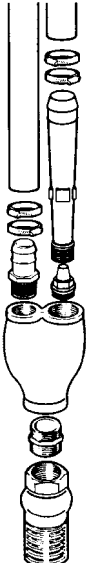

B) PIPEWORK

- i) Select the size of polyethylene pipes relevant to the injector kit No. you are using as per table below

Injector Kit No.	Suction Pipe Size	Pressure Pipe Size
29429	1 1/2"	1 1/4"
29468	2"	1 1/4"
29569	2"	1 1/2"

- ii) Having established the length of piping required for attachment to the injector (see section 4E), connect the injector assembly making sure that the larger pipe is fitted to the long venturi tube of the injector.
- iii) Use 2 hose clips on each pipe connection with worm drives on opposite sides of the pipe and tighten securely. It may be necessary to heat the polyethylene piping slightly before pushing it on to the hose tails.



6. CONNECTIONS TO PUMP

- Having installed injector and pipework down the bore, support the pipework using pipe support alternative A or B shown below.
- Complete all pipe and fittings connections to the pump as per alternative A or B below.
- It is a good idea where space allows to offset the pump from the bore by no more than 1 metre. In this way, the weight of the pipework and fittings is partially taken off the pump casing.
- Ensure all joints are air tight - use of thread seal tape or pipe joining compound is essential.
- Ensure that pipe support clamps (alternative A) or special bore cap (alternative B) are installed as a permanent fixture.
- Install a 1" gate valve on pump outlet and a pressure gauge into the priming plug.

Alternative A

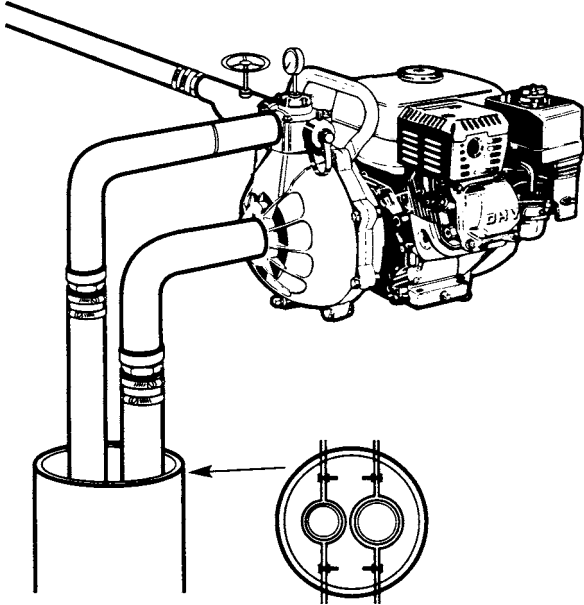

Alternative B

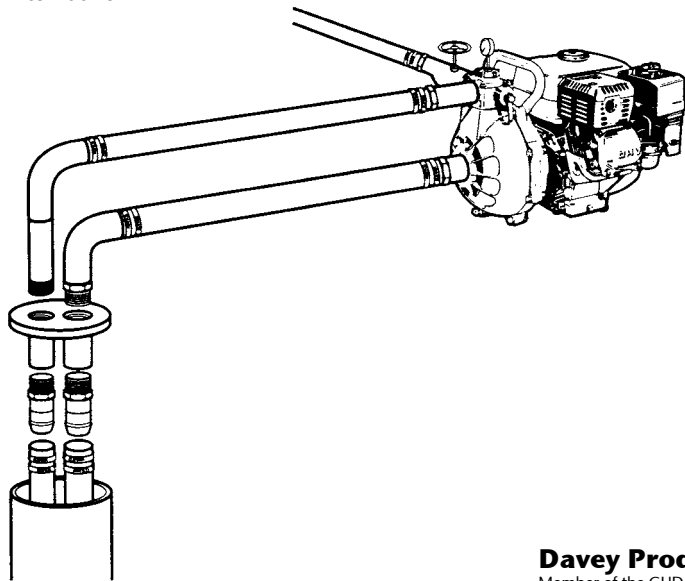

7. OPERATING THE SYSTEM

- Ensure both suction and pressure pipes are full of water* and all pipe connections are well sealed.
- Fill pump by pouring water in at the priming plug on top of the pump. Replace priming plug when all air has "bubbled" out.
- Close gate at outlet of pump.
- Start engine on pump.
- Crack blanking cap on unused outlet on 3 way discharge to expel trapped air.
- If correctly primed, pressure gauge reading will quickly climb to over 800kPa.
- On deep well installations it may be necessary to re-prime several times to expel all the air in the pipes.
- Once prime is established, set throttle at $\frac{2}{3}$ open. Engine will then be running at approx 3000rpm. Slowly open gate valve on discharge side of pump until desired flow is obtained.

***NOTE: Prior to connecting the fittings to the pump, to assist priming, the flap valve (non return valve) on the 1 1/2" inlet of the pump should be removed. Alternatively a tee installed at the top of the pressure and suction pipes may be used to add water at this point, provided that both tees are sealed and air tight. The pump must also be full of water before pump operation.**

8. MINIMUM OPERATING PRESSURES

Note that the following minimum operating pressures apply to the jet kits as follows. Set the gate valve so that when all outlets (taps, trough valves, cisterns etc) are being used, the pressure at the pump is not less than these pressures, otherwise the pump will lose prime.

MINIMUM OPERATING PRESSURE (kPa)

Injector Kit No.	Depth to water			
	12M	21M	30M	40M
29429	380	430	480	480
29468	280	310	430	460
29569	380	430	430	430

Davey Products Pty Ltd

Member of the GUD Holdings Ltd Group
ABN 18 066 327 517

Head Office and Manufacturing

6 Lakeview Drive,
Scoresby, Australia 3179
Ph: +61 3 9730 9222
Fax: +61 3 9753 4100
Website: www.davey.com.au

Customer Service Centre

Ph: 1300 367 866
Fax: 1300 369 119
E-mail: sales@davey.com.au

Interstate Offices

Sydney – Brisbane – Adelaide
Perth - Townsville

International

6 Lakeview Drive,
Scoresby, Australia 3179
Ph: +61 3 9730 9121
Fax: +61 3 9753 4248
E-mail: export@davey.com.au

Germany

Kantstrasse 47,
04275 Leipzig
Ph: +49 341 301 0412
Fax: +49 341 301 0413
E-mail: akrenz@daveyeurope.com

New Zealand

2 Rothwell Avenue,
North Harbour, Auckland 1330
Ph: +64 9 914 3680
Fax: +64 9 914 3685
Website: www.daveynz.co.nz
E-mail: sales@daveynz.co.nz

U.S.A. - Davey Pumps Inc.

1005 N. Commons Drive
Aurora, Illinois 60504
Ph: +1 630 898 6976
Fax: +1 630 851 7744
Website: www.daveyusa.com
E-mail: sales@daveyusa.com