

Priming and Operation

1. Fill pump and suction line (on flooded suction, simply open gate valve to pump). When full, fit Supercell Pressure Tank or Priming Plug as applicable.



2. Ensure outlet nearest to pump is open.



3. Ensure all valves in suction line are open and switch on.



4. Prime should establish almost immediately and a strong flow of water should be evident from the outlet. Allow water to flow for 10-20 seconds to expel air then close outlet.



5. Automatic Pressure Pumps will shut down automatically within several seconds. Manual systems must be switched off at the power point.

6. If no flow is evident from tap, switch off at power point and repeat from step 1 ensuring there is an adequate supply of water available to the pump.

Never operate your Davey Dynajet® pump for more than a few seconds without discharge flow.

Maintenance

The only regular attention your new pressure system requires is to check the pressure tank's air charge every 6 months. This can be checked at the air valve with a tyre gauge. Do not charge tank to a higher pressure than 168kPa (XJ Ultra) or 196kPa (XJ70P & XJ90P).

To check air pressure in tank:

1. Switch off pump.
2. Open outlet nearest to pump to release water pressure.
3. Remove air valve cap from top of Supercell tank and charge tank to 168kPa (XJ Ultra) or 196kPa (XJ70P & XJ90P) using air pump and check with tyre gauge.
4. Switch on.
5. Close outlet.

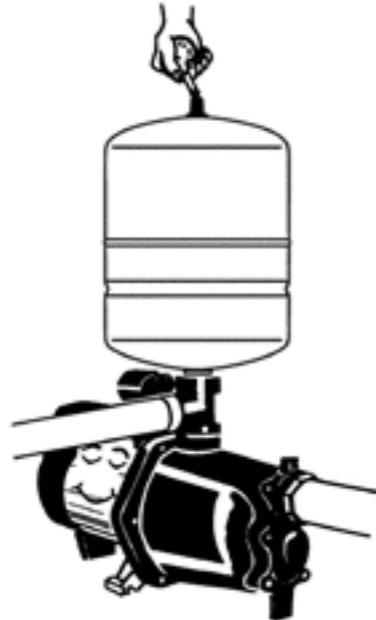

Trouble Shooting Check List

- MOTOR RUNS WHEN SWITCHED ON BUT DOES NOT PUMP.**
 1. Suction line and pump body not filled with water.
 2. Air leaks in suction lines or suction pipe not under water.
 3. Air trapped in suction lines (also possible with flooded suction due to uneven rise in piping; eliminate humps and hollows).
 4. No water at source or water level too low.
 5. Valve on suction lines closed.
- PUMP SWITCHES ON AND OFF FREQUENTLY (CYCLING) - Pressure Pumps Only**
 1. Check that tank air pressure is correct - see above.
 2. Leaking taps, float valves etc. check plumbing.
 3. Leaking check valve/foot valve.
- MOTOR DOESN'T START WHEN SWITCHED ON.**
 1. Power not connected.
 2. Supply voltage too low.
 3. "Over temperature" cut-out tripped.*
 4. Motor not free to turn eg. a jammed impeller.
 5. Internal motor fault.

***NOTE:** For protection, the Davey pump motor is fitted with an automatic "over temperature" cut-out. Constant tripping of this overload device indicates a problem eg. low voltage at pump, excessive temperature (above 45°C) in pump enclosure.

WARNING: When servicing or attending pump, always ensure power is switched off and lead unplugged. Electrical connections should be serviced only by qualified persons.

Care should also be taken when servicing or disassembling pump to avoid possible injury from hot pressurised water. Unplug pump, relieve pressure by opening a tap on the discharge side of the pump and allow any hot water in the pump to cool before attempting to dismantle.

During servicing, use only approved, non-petrochemical based oring and gasket lubrication. If unsure, consult your Davey Dealer for advice.

WARNING: Do not use hydrocarbon based or hydrocarbon propelled sprays around the electrical components of this pump.

In accordance with AS 3350.2.41 we are obliged to inform you that this pump is not to be used by children or infirm persons and must not be used as a toy by children.

After Sales Service

For professional after sales service or repair contact your Davey Dealer. For assistance in locating your nearest dealer contact the Davey Customer Service Centre on 1300 367 866



DAVEY WATER PRODUCTS GUARANTEE FOR AUSTRALIA & NEW ZEALAND
This Davey product is guaranteed to be free of material or manufacturing defects at the time of original purchase. Should any part fail as a result of such defects within two years of original purchase, the product will be repaired free of charge.

TERMS AND CONDITIONS
This guarantee applies to all states and territories of Australia and New Zealand only and is subject to the provisions of the Trade Practices Act (Aust.), the Goods and Consumer Protection Legislation of the various Australian states and the Consumers Guarantee Act 1993 (NZ) as applicable.
The guarantee period commences on the date of original purchase of the equipment. Evidence of this date of original purchase must be provided when claiming repairs under guarantee. It is recommended you retain all receipts in a safe place.
This guarantee covers parts and workshop labour only. Goods should be forwarded, with proof of date of original purchase, to an Authorised Davey Service Centre freight paid.
This guarantee is subject to due compliance by the original purchaser with all directions and conditions set out in the Installation and Operating Instructions. Failure to comply with these instructions, damage or breakdown caused by fair wear and tear, negligence, misuse, incorrect installation, chemical or additives in the water, inadequate protection against freezing, rain or other adverse weather conditions, corrosive or abrasive water, lightning or high voltage spikes or through unauthorised persons attempting repairs are not covered under guarantee. The product must only be connected to the voltage shown on the nameplate.
Without limiting the original purchaser's entitlements under the Trade Practices Act (Aust.), the Goods & Consumer Protection Legislation of the various Australian states, or the Consumers Guarantee Act 1993 (NZ), Davey shall not be liable for any loss of profits or any consequential, indirect or special loss, damage or injury of any kind whatsoever arising directly or indirectly from the product or any defect.
Where the Trade Practices Act (Aust.), the Goods and Consumer Protection Legislation of the various Australian states and the Consumers Guarantee Act 1993 (NZ) does not apply, Davey shall not be liable for any loss of profits or any consequential, indirect or special loss, damage or injury of any kind whatsoever suffered by the purchaser arising directly or indirectly from the product or any defect and the purchaser shall indemnify Davey against any claim by any other person whatsoever in respect of any such loss, damage or injury.
Nothing in this guarantee is intended to have the effect of contracting out of the provisions of the Trade Practices Act (Aust.), the Goods and Consumer Protection Legislation of the various Australian states and Consumers Guarantee Act 1993 (NZ) except to the extent permitted by the various Acts and this guarantee is to be modified to the extent necessary to give effect to that intention.
Davey may be collecting personal information from you in order to provide you with a service. Davey Water Products Pty Ltd promises only to use this information in accordance with the Provisions of the Privacy Act 1988 (Cth) and the Privacy Policy of Davey Water Products Pty Ltd which is available at davey.com.au.

© Davey and Dynajet are registered trademarks of Davey Water Products Pty Ltd. © Davey Water Products Pty Ltd 2000

Davey Water Products Pty Ltd International
Member of the GUD Group
ABN 18 066 327 517
Head Office and Manufacturing
6 Lakeview Drive,
Scoresby, Australia 3179
Ph: +61 3 9730 9222
Fax: +61 3 9753 4100
Website: davey.com.au
Customer Service Centre
Ph: 1300 367 866
Fax: 1300 369 119
E-mail: sales@davey.com.au
Interstate Offices
Sydney • Brisbane • Adelaide
Perth • Townsville

New Zealand
2 Rothwell Avenue,
North Harbour, Auckland 1330
Ph: +64 9 914 3680
Fax: +64 9 914 3685
Website: daveynz.co.nz
E-mail: sales@daveynz.co.nz

U.S.A. - Davey Pumps Inc.
1005 N. Commons Drive
Aurora, Illinois 60504
Ph: +1 630 898 6976
Fax: +1 630 851 7744
Website: daveyusa.com
E-mail: sales@daveyusa.com



Installation and Operating Instructions® for Dynajet® XJ Ultra/XJ70P/XJ90P Pressure Pumps & XJ50/XJ70/XJ90 Electric Pumps



NOTE: Prior to installation remove the red transport plugs from the suction and/or discharge.
Please pass these instructions on to the operator of this equipment.

Prior to using this pump you must ensure that:

- The pump is installed in a safe and dry environment
- The pump enclosure has adequate drainage in the event of leakage
- Any transport plugs are removed
- The pipe-work is correctly sealed and supported
- The pump is primed correctly
- The power supply is correctly connected
- All steps have been taken for safe operation

Appropriate details for all of these items are contained in the following Installation and Operating Instructions. Read these in their entirety before switching on this pump. If you are uncertain as to any of these Installation and Operating Instructions please contact your Davey dealer or the appropriate Davey office as listed on the back of this document.

Congratulations on your purchase of a high quality, Australian built Davey pressure pump. All components have been designed and manufactured to give trouble free, reliable operation.

Before installing your new pump, please read all instructions carefully as failures caused by incorrect installation or operation are not covered by the guarantee. Your Dynajet® XJ pump is designed to handle clean water. It should not be used for any other purpose without specific referral to Davey. The use of the pump to handle flammable, corrosive and other materials of a hazardous nature is specifically excluded.

XJ Ultra / XJ70P / XJ90P

1. Pressure tank (supplied separately)
2. Pressure switch
3. Delivery outlet (1" F)
4. Suction inlet (XJ Ultra = 1" F) (XJ70P & XJ90P = 1 1/4" F)
5. Pump body
6. Motor

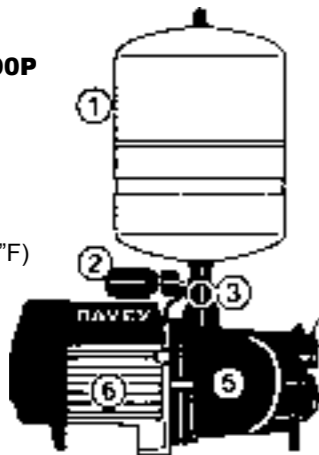

Note: Your XJ Ultra, XJ70P & XJ90P pump is designed to operate as an automatic pressure system when used in conjunction with a pressure tank such as a Davey "Supercell 18C" tank (illustrated). The tank, supplied separately, needs to be fitted to the delivery outlet prior to operating.

Assembly

Attach pressure switch (2) to the delivery outlet tee (3) by hand tightening the pressure switch union nut (ensure sealing ring is in place). Screw pressure tank (1) onto delivery outlet.

XJ50 / XJ70 / XJ90

Are the same as above less items 1 & 2.



Do not use this pump to pump flammable fluids, such as petrol or diesel fuels.

Choosing a Site

Choose a site with a firm base and as close to the water source as possible with correct power supply. Make sure your pressure system is always connected to an adequate, reliable source of clean water.

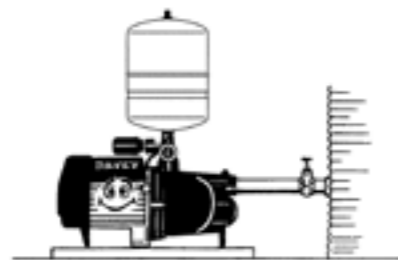

Housing your Davey Pressure System

To protect your pressure system from the weather, make sure the pump house is both water proof, frost free and has adequate ventilation. The pump should be horizontally mounted on a firm base allowing for drainage, to avoid damage to flooring etc., that over time may occur from leaking pipe joints or pump seals. Do not mount the pump vertically.



WARNING: Some insects, such as small ants, find electrical devices attractive for various reasons. If your pump enclosure is susceptible to insect infestation you should implement a suitable pest control plan.



Power Connection

Connect lead to power supply designated on pump label, do not use long extension leads as they cause substantial voltage drop, poor pump performance and may cause motor overload.

Pipe Connections

For best performance use P.V.C. or polythene pipes at least the same diameter as the pump's inlet and delivery outlet openings. Larger diameter pipe may be used to minimise resistance to flow when pumping longer distances.



Do not use pipe thread sealing compounds on any part of this pump. ONLY use Teflon sealing tape.

Use unions at pipe connections to enable easy removal and servicing. Use sufficient tape to ensure airtight seal and hand tighten only. To prevent strain on pump threads always support heavy inlet and outlet pipes. If there is a likelihood the water supply may contain solid particles such as pieces of plant or vegetable matter, a suction strainer should be installed before the pump. Lay suction pipe at a constant gradient to avoid air pockets which may reduce pump efficiency.



NOTE: Suction leaks are the largest cause of poor pump performance and are difficult to detect. Ensure all connections are completely sealed using thread tape only.

Where to use Check Valves and Foot Valves

Installations with a suction lift over 1m require a good quality foot valve to avoid loss of prime. In this case, the poppet valve inside the pump should be removed. Installations with flooded suction require a gate valve so water supply can be turned off for pump removal and servicing.

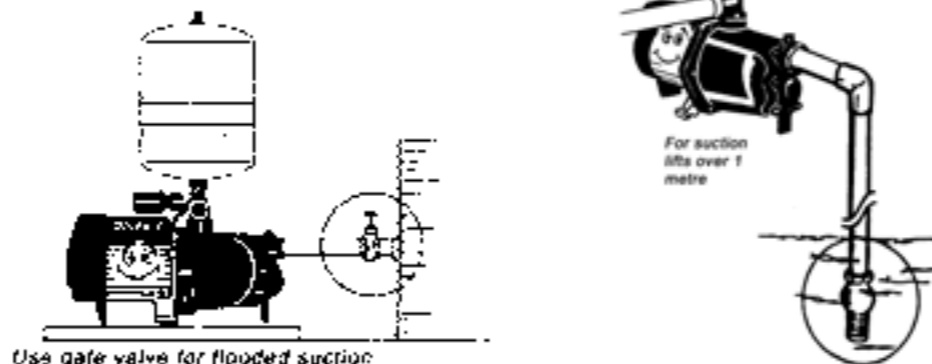

Abrasive Materials
The pumping of abrasive materials will cause damage to the pressure system which will then not be covered by the guarantee.



IMPORTANT

For Automatic Pressure Pumps Installed with a Mains Pressure Hot Water System.

A good quality non-return valve must be installed in the pressure pump outlet pipework before the hot water service. Failure to install this non-return valve may result in pump damage. Such damage is not covered by guarantee.

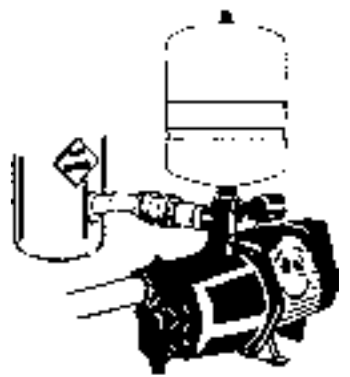

Connection of Mains Scheme or Town Water Supply to either Suction or Discharge of Pumps & Pressure Systems

Most Water Supply Authorities have strict regulations regarding direct connection of pumps to mains water supplies. In most cases an isolating tank is required between mains supply and pump. Davey also recommend this method. Directly applied mains pressure can exceed pump operating pressure and damage pump.

Davey Water Products Pty Ltd can not accept responsibility for loss or damage resulting from incorrect or unauthorised installations.

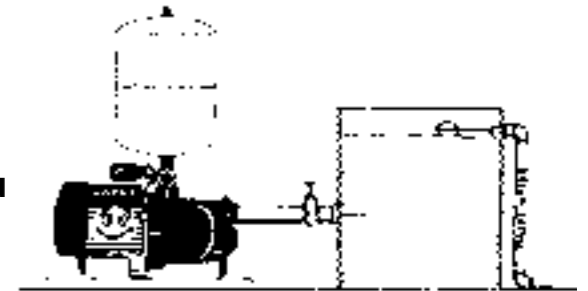

Connection to your Water Source

BELOW GROUND WATER SOURCES

Whenever the installation position of the pump is higher than 1m (3.3ft) above the lowest water level, a foot valve must be used on the end of the suction pipe as illustrated in (C) below. Ensure that the foot valve is at least 1/2 metre below minimum water level.

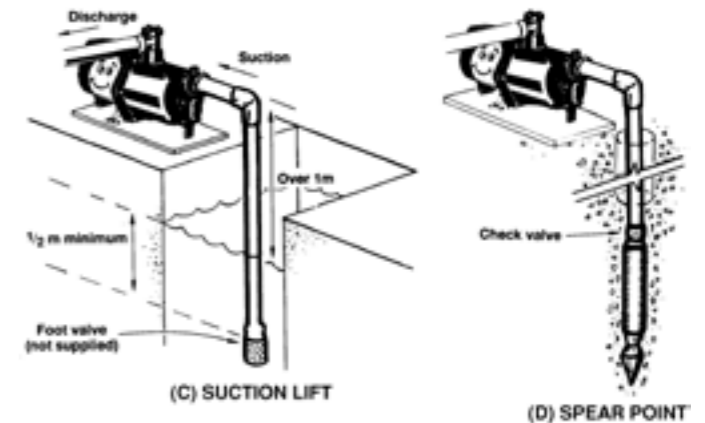

SPEAR POINT INSTALLATIONS

When a Dynajet® is installed on a spear or well point, a check valve must be fitted immediately on top of the spear point itself, as shown in (D) above. **DO NOT INSTALL THE CHECK VALVE AT THE PUMP OR AT THE TOP OF THE WELL. DO NOT RUN THE PUMP WITHOUT WATER.**

NOTE: Be certain to select the spear point to suit the well conditions and regulate the flow rate from the pump accordingly.

SPEAR SIZE POINT	MESH	APPROX. MAX. CAPACITY OF SPEAR
1 1/4" (32mm)	60	15 - 23 l/min or 200 - 300 gal/hr
1 1/2" (38mm)	60	23 - 38 l/min or 300 - 500 gal/hr
2" (50mm)	60	38 - 75 l/min or 500 - 1000 gal/hr



Spear point flow capacities vary considerably. Check with the supplier to ensure the pump and spear point are correctly matched.